

175L / 6.1 cu. ft.

UPRIGHT SOLAR DC FREEZER

UGP-175L UF



OWNER'S GUIDE

serial number:

TABLE OF CONTENTS

| | |
|------|--------------------------|
| 03 | Important safety notes |
| 07 | Installation |
| 08 | Parts list |
| 09 | DC power connection |
| 11 | Operation |
| 14 | Cleaning |
| 15 | Energy saving tips |
| 16 | Troubleshooting |
| 18 | Parts diagram and list |
| 20 | Appliance information |
| 20 | Notes |
| 21 | Contact us |
| 21 | Limited warranty |
| Back | Technical specifications |

IMPORTANT SAFETY NOTES

IMPORTANT: After transit where the freezer has been on its side or back, ensure that the freezer is in a level, upright position for 12 hours to allow compressor fluids to redistribute evenly before use.

Congratulations! You have purchased one of the most efficient refrigeration products available on the market today. The Unique 175L UF solar powered DC freezer is designed to provide years of trouble-free operation. The design is optimized for energy savings with an efficient DC compressor and highly efficient insulation.

Before using the appliance, read through this manual carefully including all the information on safety, installation, operation, and cleaning. These guidelines do not cover every possible condition or situation that may occur. Be safe using common sense and caution when installing, operating and cleaning this appliance. If you are unsure about any of these instructions or warnings, contact your local product dealer or Unique Off-Grid Appliances for assistance.

IMPORTANT SAFETY NOTES continued

- To allow the interior to cool down properly, run the freezer for at least 4 hours empty before adding food.
- This freezer is designed to operate on 12 or 24 volts DC ONLY. **DO NOT CONNECT THIS FREEZER DIRECTLY TO AN AC (alternating current) POWER SOURCE UNLESS IT'S THE SUPPLIED UNIQUE AC/DC PLUG.**
- This freezer is designed for domestic use only! It is intended for the storage of edible/consumable food and drinks. It is not intended for commercial or industrial use.
- Never use excessive force on the handle to open the door.
- If the room/ambient temperature approaches the freezer's operating temperature, the freezer may not function correctly. If the room/ambient temperature exceeds 100°F (38°C) the freezer may not function correctly.
- A DC powered freezer has a lower cooling capacity than typical AC-powered appliances. Because the compressor is small, the freezer runs more efficiently but lacks the ability to cool larger warm loads as quickly as typical AC-powered appliances.

IMPORTANT SAFETY NOTES continued

These warnings are provided in the interest of your safety. Please ensure that you understand them all before installing or using this freezer. Your safety is of paramount importance. If you are unsure about any of these meanings or warnings, contact your local product dealer or Unique Off-Grid Appliances for assistance.

PRIOR TO INSTALLATION:

At delivery, please check that the freezer is complete and has not been damaged during transport. It is not advised to connect an appliance that has been damaged, especially damage to the electrical supply cable or refrigerant circuit. In the event of damage please contact your local product dealer or Unique Off-Grid Appliances for assistance.

GENERAL SAFETY

- Before cleaning or repositioning the freezer, always disconnect from the electrical power supply.
- Service the freezer only if you are a trained or authorized refrigeration technician.
- This appliance contains refrigerant R-134a and a polyolester compressor oil in its refrigerant circuit. Take utmost care when handling your freezer so as to not cause damage to the refrigerant circuit with consequent possible leakage.
- Do not use other electrical appliances (such as ice cream makers) inside of the refrigerating appliance.

CHILD SAFETY

- **Do not allow children to play in, on or around the freezer. It is not a toy. THERE IS A DANGER OF SUFFOCATION IF A CHILD BECOMES TRAPPED INSIDE.**
- When the appliance is not in use, secure or remove the doors to prevent children from playing inside the cabinets.
- **DANGER OF SUFFOCATION** - Keep children away from all packaging material.

INSTALLATION

- This appliance is heavy. Care should be taken when moving it.
- This appliance operates on 12 or 24 Volts DC (Direct Current) only!
- Under no circumstances should this appliance be directly connected to an AC (Alternating Current) power source.
- Be sure that the appliance does not stand on the electrical

IMPORTANT SAFETY NOTES continued

supply cable. Also, be sure the electrical cable is not squeezed or bent when the appliance is being installed or moved.

- Installation work and adjustments on the appliance must be carried out by qualified personnel only. Work performed by persons with inadequate technical knowledge may adversely effect the performance of the appliance, causing damage to the equipment, and void the warranty.
- It is dangerous to make alterations or attempt to modify this product in any way. Product alterations will void the warranty.

DURING USE

- This appliance is designed for domestic use only, specifically for the storage of food and drinks. This appliance is not designed for commercial or industrial use.
- Do not store any containers with flammable vapors or liquids in or around the appliance, such as organic solvents, spray cans, gas cans, etc. **Danger of explosion!**

CLEANING

- Before cleaning always turn the freezer off and disconnect it from the electrical power supply.
- Allow inside of freezer to fully thaw, then wash the inside and outside of the appliance with luke warm water and a mild soap or detergent. Abrasive or corrosive cleaning agents, steel wool, scouring sponges, or chemical cleaning agents should not be used under any circumstances.

SERVICING

- This product should be serviced by an authorized technician and only genuine spare parts should be used.
- Under no circumstances should you attempt to repair the appliance yourself. Repairs carried out by inexperienced persons may cause injury or serious malfunctioning of the appliance. **Unauthorized work may void the warranty.**

DISPOSING OF THE APPLIANCE

- When disposing of your freezer, use an authorized disposal site. The refrigerant must be completely drained and collected by an authorized technician for recycling prior to disposal. Check with your local Environmental Agency for recommendations on recycling this appliance in your area. Remove the electrical connection wiring and also ensure that the lid is removed to prevent children from being trapped inside - **DANGER OF SUFFOCATION!**

INSTALLATION

UNPACKING AND CLEANING

Remove all packaging and securing tapes from the appliance. To avoid injury and causing damage to the appliance, be extremely cautious when using sharp or pointed tools to complete this task. Keep children away from the packaging material - **DANGER OF SUFFOCATION!** Wash the inside and outside of the appliance with luke warm water and a mild soap or detergent. Abrasive or corrosive cleaning agents, steel wool, scouring sponges, or chemical cleaning agents **should not** be used under any circumstances. A sponge, soft brush or towel is recommended. After cleaning, thoroughly rinse and dry. You may want to leave the doors open allowing the compartments to ventilate for 20-30 minutes to get rid of residual odors. Check with your local Environmental Agency for recommendations on recycling packaging materials in your area.

POSITIONING THE APPLIANCE

The area in which the freezer is to be installed must be relatively cool, dry, and suitably ventilated. The area must be protected against any inclement weather (rain, snow) and excessive surface dust. To ensure proper function, the appliance must be placed on a flat, firm, and stable surface resting level on all four supports. The floor must be strong enough to support a fully loaded cabinet. Use wood or metal shims to level the freezer if necessary.

Do not place the freezer close to heat sources (heater, stove, boiler, chimney, etc.), and avoid prolonged exposure to direct sunlight. This appliance uses the exterior walls to transfer heat from the inside of the cabinet. Ensure that there is adequate space between the freezer and neighboring walls or large objects. A minimum spacing of 3 inches (7.5 cm) is highly recommended. This will provide sufficient airflow around the appliance resulting in more efficient operation and longer appliance lifetime. Always keep the air vent openings of the compressor housing cover free from dust and obstructions.

PARTS LIST

PARTS LIST

- 1: Storage drawers
- 2: Thermostat
- 3: Door
- 4: Adjustable feet
- 5: Ice tray
- 6: Power cable
- 7: AC/DC Plug (sold separately for 110V application)

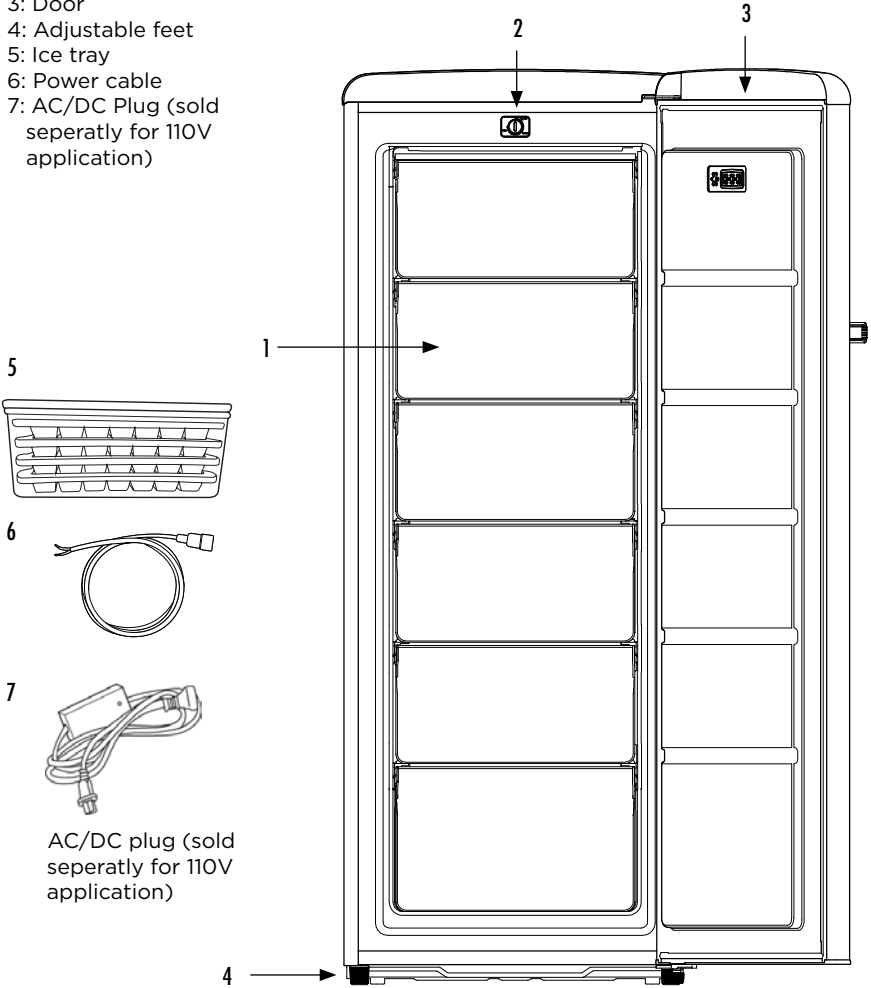

DC POWER CONNECTION

THIS FREEZER MUST NEVER BE CONNECTED DIRECTLY TO ANY AC (alternating current) POWER SOURCE!

THE FREEZER MUST ONLY BE CONNECTED TO A 12V OR 24V DC POWER SOURCE, SUCH AS A SOLAR BATTERY SYSTEM OR CHARGE CONTROLLER.

THE FREEZER WILL AUTOMATICALLY OPERATE ON EITHER 12V OR 24V DC. THE USER DOES NOT NEED TO MAKE ANY ADJUSTMENT.

ATTENTION: Polarity is important in wiring this DC appliance. Be sure that the positive terminal of the battery or charge controller coincides with the positive wire to the compressor, and the negative terminal of the battery or charge controller coincides with the negative wire to the compressor. The leads should be connected using cable shoes and screwed connections. Joined leads should be avoided.

+ to + and - to -

**positive to positive / negative to negative
(red wire) / (black wire)**

ELECTRICAL DIAGRAM

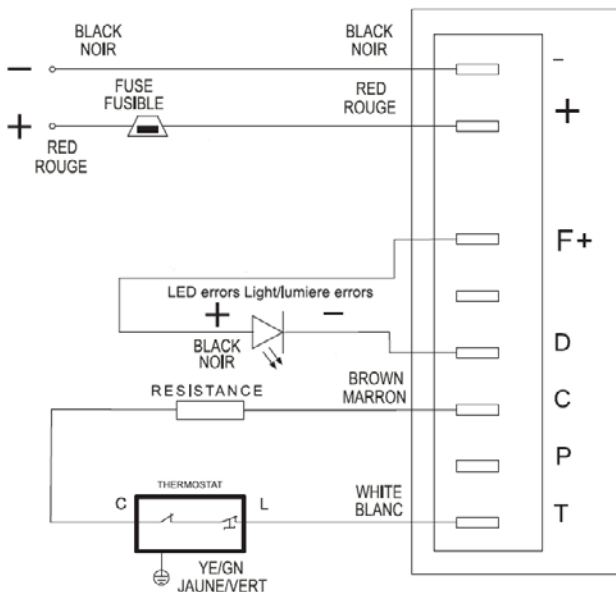

DC POWER CONNECTION continued

IN-LINE FUSE

A 15A in-line fuse is provided with this freezer in order to protect the wiring. **For 12V/24V operation, use a 15A fuse.** A standard automobile fuse is recommended and the fuse should be wired to the positive (“+”) side of the system close to the positive battery terminal.

A 15A fuse is provided with this freezer.

| OPERATING VOLTAGE | FUSE |
|-------------------|------|
| 12 V / 24 V | 15 A |

ATTENTION

If a longer connection cable is necessary, the cable cross section (or gauge) must be equal to or greater than the cable sizes recommended on the following table. Be careful that the input voltage at the appliance does not drop below the cut-out voltage of the compressor.

| CABLE SIZE | | 12V CABLE LENGTH | | 24V CABLE LENGTH | |
|--------------------------------------|-------|------------------|------|------------------|------|
| AREA | AWG | | | | |
| mm ² /inch | Gauge | m | ft | m | ft |
| 2.5 / ³ / ₃₂ ” | 12 | 2.5 | 8 | 5 | 16 |
| 4 / ⁵ / ₃₂ ” | 12 | 4 | 13 | 8 | 26 |
| 6 / ¹⁵ / ₆₄ ” | 10 | 6 | 19.5 | 12 | 39 |
| 10 / ²⁵ / ₆₄ ” | 8 | 10 | 32.8 | 20 | 65.6 |

LOW VOLTAGE DISCONNECT

The compressor electronics includes a low voltage disconnect feature. If the input voltage to the appliance falls below 10.4V (in 12 V mode) or 22.8V (in 24 V mode), the compressor will shut-off. Once the voltage increases above 11.7V (in 12V mode) or 24.2V (in 24V mode), the compressor will resume normal operation.

This feature is designed to protect the system battery from experiencing too low a depth of discharge.

| | 12 V OPERATION | 24 V OPERATION |
|----------|----------------|----------------|
| SHUT-OFF | 10.4 V | 22.8 V |
| RESTART | 11.7 V | 24.2 V |

OPERATION

Your Unique freezer, like any battery-powered refrigerating appliance, requires different care than appliances plugged into an electric utility. Prudent operation is the key to extended service.

STARTING THE FREEZER

After the freezer has been properly connected to the 12 or 24 V DC power source, the compressor will automatically turn on and the cabinet will begin cooling. Allow the cabinet to cool for at least 4 hours prior to adding foodstuff.

TEMPERATURE CONTROL

The temperature within the freezer compartments is controlled by the thermostat situated on the top of the freezer area. When you first start the freezer we suggest that you turn the thermostat to a maximum setting until desired freezer temperatures are achieved. The correct internal temperature setting can be found by measuring the temperature of the central or middle portion in the appliance.



| NORMAL OPERATING TEMPERATURE RANGE (in the ambient 25°C / 77°F) | |
|---|-------------------------------|
| THERMOSTAT SETTING | FREEZER TEMPERATURE |
| *Optimal Setting = 1.6 | -10°C to -15°C 14°F to 5°F |
| Setting = 4 | -25°C / 5°F |
| NOTE: Setting 1 being warmest and 4 coldest | |

***NOTE:** Mechanical temperature controller has a + or - , 0.5 range. The freezer will run a few degrees colder at high elevations.

OPERATION continued

ADJUSTMENTS

As the ambient temperature changes with the season, it may be necessary to adjust the thermostat to achieve the proper internal temperature. If the room/ambient temperature approaches the appliance's internal operating temperature, the appliance will not function as it should. The appliance will tend to run colder during these conditions and it may be necessary to turn the thermostat to a warmer setting (lower number). If the room/ambient temperature exceeds 100°F (38°C), the appliance will not function as it should. The appliance will tend to run warmer and it may be necessary to turn the thermostat to a colder setting (towards the maximum setting).

OPENING AND CLOSING THE DOOR

The doors are fitted with uniform sealing strips to prevent warm air and moisture from entering the freezer compartments.

Be sure that the doors and door seals are free from obstructions and form a complete seal around the rim of the freezer cabinets. Overstuffing and/or unlevel installation of the appliance will prevent a good seal.

It might be hard to open the door immediately after the door is closed. This is due to air contraction in the freezer cabinets. This pressure difference will equalize in a few seconds, making the doors easy to open once again.

LOADING THE FREEZER

A battery-powered refrigeration appliance has a cooling capacity lower than typical AC appliances. Because the compressor is smaller, the appliance runs more efficiently but cools warm or room temperature food at a slower rate than an AC appliance.

Avoid packing food too tightly around the cooling plates located on the back wall of the freezer. Allow air flow around these plates to ensure proper operation.

When adding unfrozen food to the freezer for the first time, fill the freezer only 1/3 full and wait until that food is sufficiently frozen before adding more. It will also help to cool food more quickly if the food is packaged in smaller containers rather than large ones. Food packages more than 2 inches thick will cool slowly. Avoid placing warm food in contact with cold food.

NORMAL OPERATING SOUNDS

- You may hear faint gurgling or bubbling sounds when the refrigerant is being pumped through the refrigerant coils.
- When the compressor is on, the refrigerant is being pumped through the appliance and you will hear a whirring or pulsing sound from the compressor.

12 • A thermostat controls the compressor and you may hear a 'click' when the thermostat cuts in and out.

OPERATION continued

DEFROSTING

Before cleaning or repositioning the freezer, you must **DISCONNECT** the appliance from the electrical power supply.

DEFROSTING THE UNIT As solar freezers do not have automatic defrost the freezer compartment will become progressively covered with frost. This should be removed periodically with a plastic scraper. However, when the ice becomes very thick on the interior walls, complete defrosting should be carried out. Perform this operation when the appliance is empty and disconnected from the power supply.

NEVER USE SHARP METAL TOOLS TO SCRAPE OR CHIP OFF FROST FROM THE INTERIOR COMPARTMENT AS THIS COULD DAMAGE THE APPLIANCE BEYOND REPAIR. DO NOT USE HEAT SOURCES SUCH AS ELECTRIC OR GAS HEATERS TO COMPLETE THE DEFROST PROCESS.

To perform a complete defrosting:

1. Disconnect the appliance from the electrical supply.
2. Remove any stored food and store in coolers, or wrap in several layers of newspaper and store in a cool place.
3. Leave the doors open.
4. To accelerate the defrosting process, place a bowl of hot (not boiling) water inside the freezer compartments and close the door.
5. When defrosting is complete, wash and dry the interior thoroughly.
6. Reconnect the appliance to the electrical supply and leave running (while empty) for at least 2 hours allowing the interior to cool sufficiently.
7. Reload the freezer with the previously removed food.

ATTENTION: Partial thawing of frozen food during defrosting may shorten its safe storage life-span.

OPERATION continued

Operational errors

| Error code or LED flashes | Error type |
|---------------------------|--|
| 6 | Thermostat failure (If the NTC thermistor is short-circuit or has no connection). |
| 5 | Thermal cut-out of electronic unit (If the refrigeration system has been too heavily loaded, or if the ambient temperature is high, the electronic unit will run too hot). |
| 4 | Minimum motor speed error (If the refrigeration system is too heavily loaded, the motor cannot maintain minimum speed at approximately 1,850 rpm). |
| 3 | Motor start error (The rotor is blocked or the differential pressure in the refrigeration system is too high (>5 bar)). |
| 2 | Fan over-current cut-out (The fan loads the electronic unit with more than 0.5A _{avg}). |
| 1 | Battery protection cut-out (The voltage is outside the cut-out setting). |

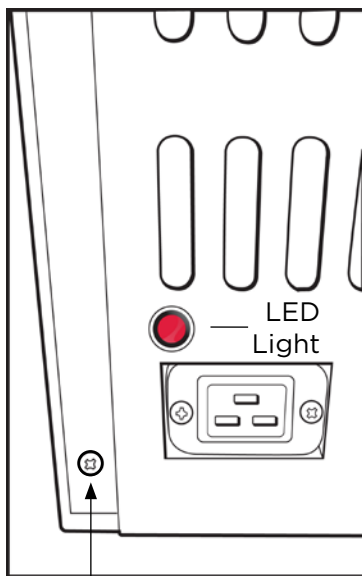

Remove 4 screws from grates to access 15A fuse

NOTE: When freezer is connected to a power adaptor or to a battery, light indicator will not light up.

CLEANING

Internal Cleaning

Wash the inside of the appliance with luke warm water and a mild soap. Never use abrasive or corrosive cleaning agents, steel wool, scouring sponges, chemical cleaning agents, or highly perfumed cleaning products to clean the interior as these will damage the surface and leave behind a strong odor. A sponge, towel, or soft brush is recommended. Wash with a mixture of two tablespoons (30ml) of baking soda to 1 quart (1.14L) warm water. After cleaning, wipe all surfaces with a soft cloth and clean water to rinse, and allow the freezer to dry.

External Cleaning

Wash the outside of the cabinet with warm water and a mild soap or detergent.

Do not use abrasive or corrosive cleaning agents, chemical cleaning agents, steel wool or scouring sponges to clean the freezer as it may cause damage to the surfaces.

ENERGY SAVING TIPS

- Do not install the freezer close to sources of heat, such as a stove, boiler, heater, chimney, etc, and avoid exposure of the appliance to direct sunlight.
- Locate the appliance in a cool well-ventilated room and make sure that the air vents of the compressor housing cover are not obstructed. Also allow adequate spacing around the cabinet for air circulation (3" or 7.5cm)
- Avoid unnecessary frosting in the cabinet by packing all food and liquids in airtight packages or containers.
- Always keep food stored in tightly sealed packaging or containers, and allow some space for air to circulate around each item.
- Avoid keeping the door open for extended periods of time or opening the door too frequently as warm air will enter the cabinet and cause the compressor to run unnecessarily often.
- Ensure there are no obstructions preventing the doors from closing properly and forming a tight seal.

TROUBLESHOOTING

Before contacting a service technician, your local product dealer or Unique Off-Grid Appliances, please check the following points. If you contact a technician to repair a fault listed below, or to repair a fault caused by misuse, abuse, or faulty installation, a charge will be made even if the appliance is under warranty.

| PROBLEM | SOLUTION |
|--|--|
| Appliance is connected to power, but does not operate | <ul style="list-style-type: none">• Check if 12V or 24V DC is present at the appliance. If not, check all connections and the system battery voltage.• Check that the polarity is correct: positive (+) is connected to positive (+), and negative (-) is connected to negative (-).• Check the fuse. If blown, replace with a new one (see page 11 for details).• The primary problem with a non-functioning appliance is due to a voltage drop to the compressor, which causes the unit to fail to start due to “low voltage”. Typically a connection is not as tight as it should be, or the wire size to the compressor is too small. The low voltage problem occurs instantly at start-up and can be difficult to detect with a volt meter because it happens so quickly (<100ms) |
| Appliance is operating, but the interior (cabinet) is not cold | <ul style="list-style-type: none">• Allow the appliance at least 4 hrs to cool down once turned on.• Check that the thermostat control knob is turned to the correct setting relevant to the room/ambient temperatures.• Check that the room/ambient temperature is not approaching the internal operating temperature and does not exceed to 100° F (38° C).• Has too much warm food been added to the freezer recently? If so, it will take some time for the appliance to return to temperature.• Does the cabinet have adequate ventilation around the side walls, allowing it to transfer heat properly? (See Installation section) |
| The door will not open | <ul style="list-style-type: none">• Has the door just been opened? If so, leave the appliance closed for a few minutes to allow the air pressure to equalize and try again. |

TROUBLESHOOTING continued

| | |
|--------------------------------------|--|
| Excessive frost and ice has built up | <ul style="list-style-type: none">• Is the weather hot and humid? If so, this will increase the rate of frost build-up in the cabinet.• Ensure that stored food is properly packaged.• Check that the door is closed and has a good seal, and that nothing is preventing the door from closing properly.• Large quantities of food have recently been placed in the freezer, and/or the door is frequently opened.• Ensure that proper care and maintenance of the appliance has been performed (cleaning, defrosting, etc...) |
| Noise | <ul style="list-style-type: none">• Refer to “Normal Operating Sounds” (page 13) |
| Light does not work | <ul style="list-style-type: none">• Remove cover and check light bulb - replace if necessary. |

CUSTOMER RESPONSIBILITIES

The following items are the responsibility of the customer and are not covered by the warranty:

- Proper care and use of the appliance as described in this manual.
- Damage to the interior or exterior finish or components after delivery.
- Proper power supply, fuse, wiring, and connections.
- Service required as a result of alteration, misuse, abuse, flooding, fire, lightning, or other acts of God.

UGP-175L UF PARTS DIAGRAM AND LIST

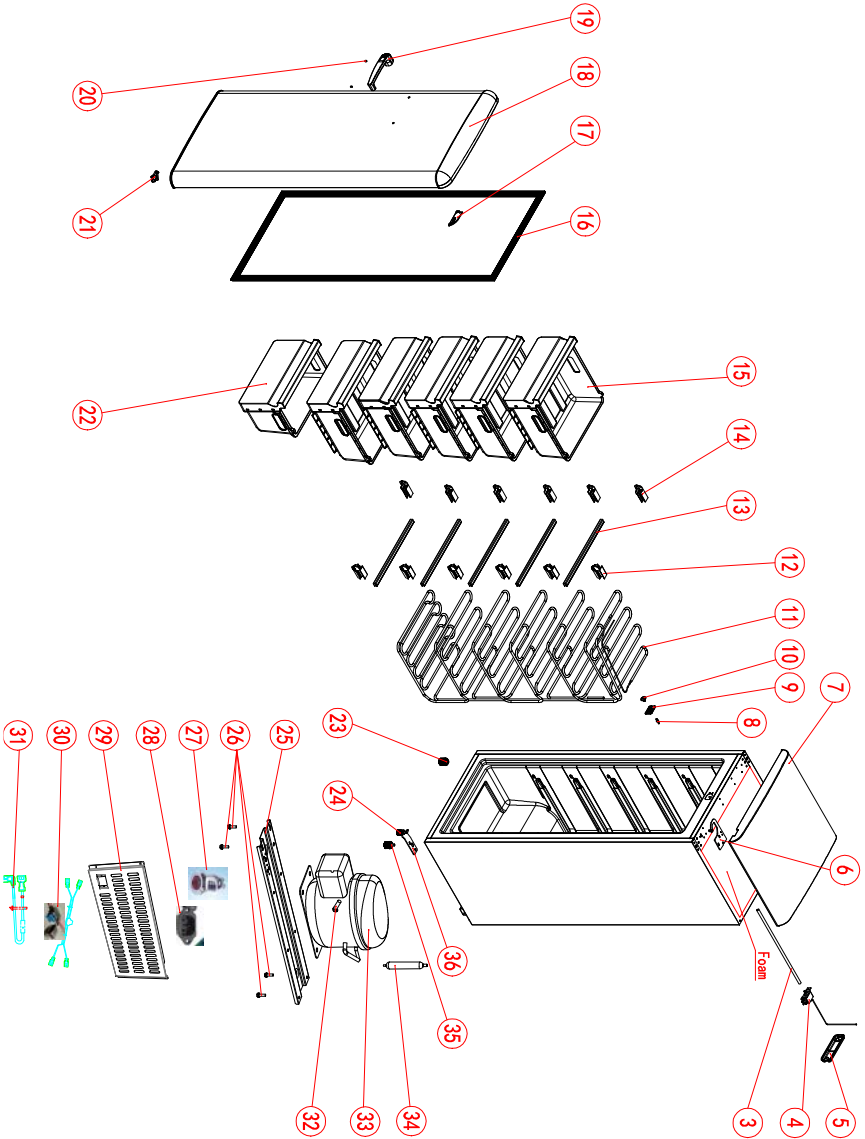

PARTS DIAGRAM AND LIST continued

| ITEM # | PART # | DESCRIPTION |
|--------|-------------|----------------------------------|
| 3 | UGP-175L-3 | Thermostat adjustment lever |
| 4 | UGP-175L-4 | Thermostat |
| 5 | UGP-175L-5 | Thermostat back cover |
| 6 | UGP-175L-6 | Upper hinge group |
| 7 | UGP-175L-7 | Top cover |
| 8 | UGP-175L-8 | Thermostat knob connecting parts |
| 9 | UGP-175L-9 | Thermostat display Cover |
| 10 | UGP-175L-10 | thermoregulation knob |
| 11 | UGP-175L-11 | F evaporator |
| 12 | UGP-175L-12 | Restrict block right |
| 13 | UGP-175L-13 | Ornament strip |
| 14 | UGP-175L-14 | Restrict block left |
| 15 | UGP-175L-15 | Upper drawer |
| 16 | UGP-175L-16 | Door seal |
| 17 | UGP-175L-17 | Upper strongback hinge cover |
| 18 | UGP-175L-18 | Door |
| 19 | UGP-175L-19 | Handle |
| 20 | UGP-175L-20 | Hexagon cone screws |
| 21 | UGP-175L-21 | Aided sucker apparatus |
| 22 | UGP-175L-22 | Bottom drawer |
| 23 | UGP-175L-23 | Adjustable foot |
| 24 | UGP-175L-24 | Low adjustable foot |
| 25 | UGP-175L-25 | Compressor base |
| 26 | UGP-175L-26 | Flange screw |
| 27 | UGP-175L-27 | Trouble light |
| 28 | UGP-175L-28 | Plug |
| 29 | UGP-175L-29 | Back cover |
| 30 | UGP-175L-30 | Compressor connect cable |
| 31 | UGP-175L-31 | The speed resistance cable |
| 32 | UGP-175L-32 | Process tube |
| 33 | UGP-175L-33 | DC Compressor |
| 34 | UGP-175L-34 | Low adjustable foot |
| 35 | UGP-175L-35 | Lower hinge parts |

UNIQUE®

APPLIANCE INFORMATION (manual copy - keep with your records)

To make care and servicing of your solar powered DC freezer easy and efficient, please record the following information for future reference:

Model:

Serial Number:

Purchased From:

Date Purchased:

NOTES

UNIQUE®

CONTACT US

For questions related to the operation, safety or the purchase of your freezer, please contact your dealer for more information. For general information, contact our customer service department:

- Toll-free: 1-877-427-2266 or 1-905-827-6154 (available during regular business hours, 8:30 am to 4:30 pm, EST).
- Email: info@UniqueOffGrid.com Website: www.uniqueoffgrid.com
- Address: Unique Gas Products Ltd., 2245 Wycroft Road, Oakville, Ontario, Canada, L6L 5L7

175L UF SOLAR POWERED DC FREEZER 1 YEAR LIMITED WARRANTY

Unique Gas Products Ltd. warrants that this UNIQUE freezer is free from defects in material and workmanship under normal usage and service under the following terms:

Parts Warranty

This appliance has been designed for domestic household use. If properly installed, adjusted and operated under normal conditions in accordance with printed instructions, it will satisfactorily perform the functions that are generally expected of this type of appliance.

If the appliance fails to do so because of a defect in material or workmanship within one year from the original date of purchase: Unique will at our option, repair, exchange, or correct by other means Unique consider appropriate, any part(s) Unique finds to be defective except for the surface finish. *Due to remote locations, it is the customer's responsibility to bring items to the dealer for review. Any part(s) replaced or repaired will be warranted only for the balance of the original year. Customer is responsible for labor.

Ownership

This Warranty is made only to the first purchaser ("original purchaser") who acquires this freezer for his/her own use and will be honored by Unique Gas Products Ltd. and by the Seller. Purchaser must retain their receipt as proof of purchase date.

Warranty Conditions

This warranty does not apply to any appliance that has been subjected to alterations, misuse, abuse (including damage by foreign agents or chemicals), accident, improper installation or service, delivery damage, or other than normal household use and service. This UNIQUE appliance must be serviced regularly as outlined in the Owner's Manual. Neither Unique Gas Products Ltd. nor the selling dealer will be liable for direct or indirect loss of foods caused by failure in operation. In case of damage, the owner must provide proof of purchase, Model, and Serial Number to the selling dealer or Unique Gas Products Ltd. This warranty is LIMITED STRICTLY to the terms indicated herein, and no other expressed warranties or remedies thereunder shall be binding on Unique.

Purchaser's Responsibilities

The purchaser will be responsible for the costs of any service calls requested to demonstrate or confirm the proper operation of the appliance, the installation, or to correct malfunctions in the appearance created by the operation of the appliance in a manner not prescribed by or cautioned against in the use and care instructions.

Model and Serial Number

The appliance model number and serial number can be found on a rating plate attached at the back of the freezer. The purchaser should always refer to the model and serial number when talking to or contacting the dealer from whom the appliance was purchased.

Factory Assistance

If the purchaser is unable to locate an authorized dealer/service agent, or if the purchaser does not receive satisfaction from the dealer, they may contact Unique Gas Products Customer Service directly at Toll Free 1-877-427-2266 or 905-827- 6154

TECHNICAL SPECIFICATIONS

| MODEL | UGP-175L UF |
|--|---|
| SIZE | total: 6.1 cu/ft, 175 litres |
| OPERATION | •12V/24V |
| DIMENSIONS (unboxed) | H 56.7" x W 21.6" x D 24" H 144 cm x W 55 cm x D 61.5 cm |
| WEIGHT | 102.5 lbs./46.5 kg |
| DC POWER | 12V/24V |
| TOTAL WATT HR. PULL DOWN (24 DC) | 695 Wh/24hrs (set to -13°C freezer performance in a +25°C ambient) |
| TOTAL WATT HR. STABLE RUNNING (24 DC) | 532 Wh/24hrs (set to -13°C freezer performance in a +25°C ambient) |
| POWER CONSUMPTION 12V/24V | 58.8 W |
| AV. RUN CURRENT | 4.9A on 12V - 2.5A on 24V |
| FREEZER TEMP. RANGE | -6°C to -25°C |

UNIQUE®