

DLS SERIES BATTERY CHARGERS & POWER CONVERTERS

DUAL-STATE
LINE / LOAD CONTROL
SWITCH-MODE

CONVERTS **120VAC** TO **12VDC** **15 AMP**



RoHS
COMPLIANT

to protect our environment

DESIGNED FOR SUPERIOR 120VAC / 12VDC PERFORMANCE

IOTA's 120VAC to 12VDC DLS Series Converter/Charger designs provide clean, steady output for efficient battery charging and confident operation of your DC equipment. The compact, durable engineering of the DLS Series combines reliable AC/DC performance with whisper-quiet operation and lower operating temperature. IOTA's **Dual State Charging**, tight **Line/Load Control** and **Switch-Mode** design make the DLS Series a powerful, efficient, and compact battery charging and power conversion solution for almost any application!

DLS-15-X AC/DC CONVERTER / CHARGER



The DLS-X delivers a 'next level' charging experience by combining IOTA's powerful AC/DC conversion DLS technology with newly enhanced user features...robustly engineered and manufactured for extra performance in harsher electrical conditions and fully covered under our extended **Three-Year Warranty**.



Extreme compact design features a reduced height for low clearance compartments.



Expertly engineered and manufactured with durable componentry for added confidence and long-life in harsh electrical applications.



Expanded terminal block UL rating to accommodate 2 gauge connection for greater installation distance and less voltage drop.



AC Power Indicator lets you know your DLS-X is receiving power and ready to charge.



Exceptional cooling efficiency means minimized venting for increased protection against debris and other elements.



External docking compartment for optional IQ4-X four-stage smart-charging module.



Two mounting footprint options with included mounting adaptor plate.



Extended Three-Year Warranty.

DLS-15 AC/DC CONVERTER / CHARGER



IOTA's DLS Series has a proven track record of exceptional performance for battery charging and AC/DC power conversion. Designed for efficient and clean DC output for confident operation in electrical systems in a wide range of industries.



Dual Voltage jack allows for manual selection between Normal and Absorption Phase charging as well as easy installation of the IQ4 Smart Charge Controller.



Can be used with the optional IQ Smart Charge Controller for automatic multi-stage charging to prevent battery sulfation and stratification.



Standard Two-Year Warranty.

BATTERY TECHNOLOGY

The DLS and DLS-X Series are compatible with Deep-Cycle, VRLA, Gel, AGM, Flooded Lead-Acid, and Select NiFe and Lithium Battery Types. Some battery technologies require proper battery management systems and may require a specific IQ smart charging control profile for optimal performance. Contact our Technical Services Team for the right IOTA charging solution for your application.



RATINGS AND SPECIFICATIONS

15A DLS

DC Output Voltage (No Load) approx.	13.6V (DC)
Output Voltage Tolerance (No Load)	+ or - .7%
Output Amperage, Max Continuous	15 Amps
Output Voltage (Full Load) approx.	>13.4V (DC)
Max. Power Output, Continuous	200W
Ripple and Noise	<50 mV rms
Input Voltage Range	108 - 132 VAC
Input Voltage Frequency	47-63
Maximum AC Current (@108Vac)	3.7 Amps
Typical Efficiency	>80%
Max Inrush Current, Single Cycle	30 Amps
Short Circuit Protection	Yes
Overload Protection	>100%
Line Regulation	100 mV rms
Load Regulation	<1%
Fan Control	PROPORTIONAL
Thermal Protection	YES
Working Temperature Range	0° - 40° C
Storage Temperature	-20° to 80° C
Withstand Voltage (VDC) [†]	1700/1700/500
Weight	4.5 lbs

[†]Primary to Chassis/Primary to Secondary/Secondary to Chassis

STATE-OF-THE-ART INDUSTRIAL DESIGN...

Dual-State Charging

IOTA's Dual-State Charging design allows the unit to function as both a constant voltage or a constant current charger and automatically selects the optimal charging method for your battery's needs, resulting in safer, faster, and more efficient charging.

Line / Load Control

The tight line/load control of the DLS allows for clean conversion of AC voltage into steady and reliable DC power for your battery or load. By preventing erratic DC output, the DLS Series allows confident operation of onboard and sensitive equipment for optimal life and prevents damage or equipment shutdown from unexpected overloads.

Switch-Mode Technology

The IOTA DLS Series uses state-of-the-art switch mode technology, which minimizes wasted power by significantly reducing high dissipation states. The switch-mode design allows for reliable, efficient performance in a compact chassis with lower operating temperature.

ADDITIONAL FEATURES



Built-in protection features against low transient AC line voltage, and current limit and thermal overload protection.



Proportional Fan Control provides 'whisper-quiet' operation, utilizing the fan only when needed and at minimal speeds, eliminating sudden and obtrusive start-up noise.



External Reverse Polarity automotive blade-type protect the unit in the event of incorrect battery hookup.



UL Listing for United States and Canada.

DIMENSIONS

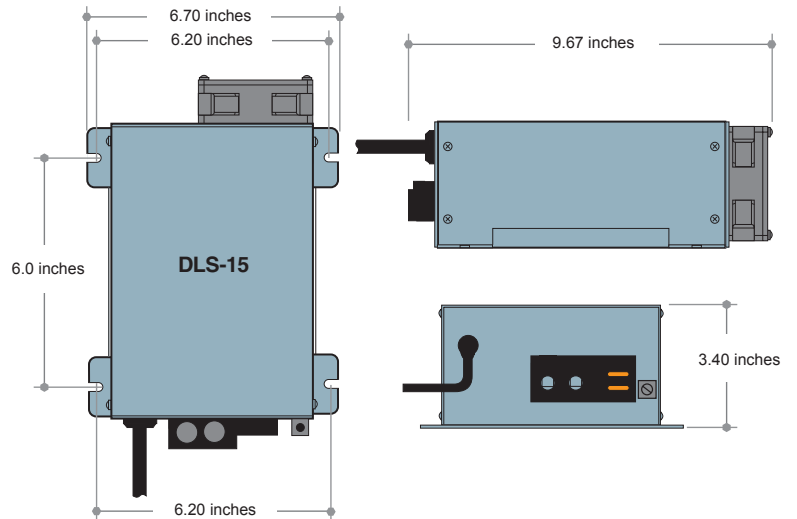
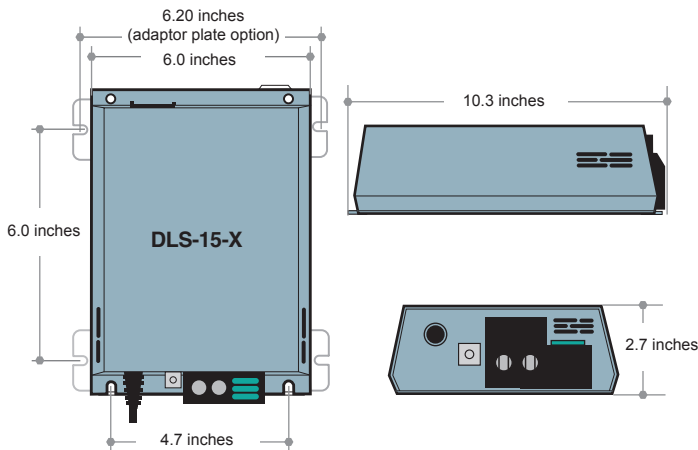

A.C POWER CORD

Both the DLS-15 and DLS-15-X utilize a standard NEMA 5-15 cord (approx. 36-inch length) for connection to a 15A receptacle.

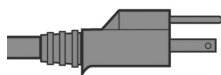

4-STAGE SMART CHARGING OPTIONS

Optional 4-stage smart-charging is available for both the DLS and DLS-X Charger Converter. Four-stage smart-charging ensures fast, efficient charging and protects your battery from the potential of boiling, sulfation and stratification with Bulk, Absorption, Float, and Equalization stage charging. For the DLS, use the IQ4. For the DLS-X, use the IQ4-X. Contact Customer Service or visit www.iotaengineering.com/iq.htm for further information.